



Meets the essential requirements as described in the European Directive 2009/142/EC



**DANGER - IF YOU SMELL GAS**

1. Shut off gas to the appliance.
2. Extinguish any open flame.
3. If odor continues, keep away from the appliance and immediately call your gas supplier or fire department.



**WARNING**

Do not store or use gasoline or other flammable vapors and liquids in the vicinity of this or any other appliance. An LP-cylinder not connected for use shall not be stored in the vicinity of this or any other appliance.



**DANGER**



**CARBON MONOXIDE HAZARD**

This appliance can produce carbon monoxide which has no odor.

Using it in an enclosed space can kill you.

Never use this appliance in an enclosed space such as a camper, tent, car or home.



**WARNING:**

Improper installation, adjustment, alteration, service or maintenance can cause injury or property damage. Read the installation, operating and maintenance instructions thoroughly before installing or servicing this equipment.



**WARNING: FOR OUTDOOR USE ONLY!**



## WARNINGS:

**IMPORTANT:** This appliance should be inspected before use and at least once annually by a qualified service person.

More frequent cleaning may be required as necessary. It is imperative that the control compartment, burners and circulating air passageways of the appliance be kept clean.

**DANGER:** Carbon monoxide poisoning can lead to death!

### CARBON MONOXIDE POISONING:

Early signs of carbon monoxide poisoning resemble the flu, with symptoms including headache, dizziness, or nausea. If you experience these signs, the Fire Pit may not be working properly. Get fresh air at once! Have the Fire Pit serviced. Some people are more affected by carbon monoxide than others, including pregnant women, people with heart or lung disease or anemia, those under the influence of alcohol, and those at high altitudes.

### NATURAL GAS AND PROPANE:

To assist in detecting leaks, an odorant has been added to natural gas and propane. However, this odorant can fade, and gas may be present even though no odor exists. Make certain you read and understand all warnings. Keep this manual for reference. It is your guide to safe and proper operation of this appliance.

**WARNING:** Any modification to this appliance or its controls can be dangerous.

Read instructions before installation and use.

1. This appliance, as supplied, is only for use with the type of gas indicated on the rating plate.
2. This appliance is intended to be connected to a fixed piping system. The installation must conform to local and/or national codes.
3. Never leave the fire unattended.
4. Keep the appliance area clear and free from combustible materials, gasoline and other flammable vapors and liquids
5. Use only the type of gas that is specified by the manufacturer.
6. Do not burn solid fuel in this appliance. Do not use this appliance to cook food or to burn paper or other objects.
7. Children and adults should be alerted to the hazards of high surface temperatures and should stay away to avoid burns or clothing ignition.
8. Clothing or other flammable materials should not be hung from the appliance, or placed on or near the appliance.
9. Young children should be carefully supervised when they are in the area of the appliance.

10. Do not use the appliance if any part has been under water. Immediately call a qualified service technician to inspect the appliance and to replace any part of the control system and any gas control which has been under water.
11. In case of violent wind particular attention must be taken against the tilting of the appliance.
12. Inspect the appliance before each use.
13. Do not move the appliance when in operation. Shut off gas at source before moving the appliance
14. Turn the appliance off and let cool before servicing, installing, repairing or covering. Any guard or other protective device removed for servicing the appliance must be replaced prior to operating the appliance. Only a qualified service person should install, service, or repair the appliance.

### FOR OUTDOOR USE OR IN AMPLY VENTILATED AREAS

- An amply ventilated area must have a minimum of 25% of the surface area open.
- The surface area is the sum of the walls surface

1. UNPACK: Account for all parts (p 15-16)
2. FRAGILE: Handle with care
3. LEVEL: Place on a solid, level surface
4. ANCHOR: We recommend anchoring this unit to the ground
5. AIR VENTS: Do not block ventilation gaps (p 4 & p 5)
6. GAS LINE: Supply line must be routed through the base of the unit and must be installed by a licensed tradesperson
7. MEDIA TOPPINGS: Review correct placement (p7-8)

CAUTION (where applicable): COR-TEN STEEL is designed to oxidize and form a protective layer that resists corrosion. This layer can take several months to stabilize depending on climate and weather conditions.  
Rust will bleed until it stabilizes.

Do not place Cor-Ten fire pits on surfaces that will be permanently damaged or stained by rust bleed.

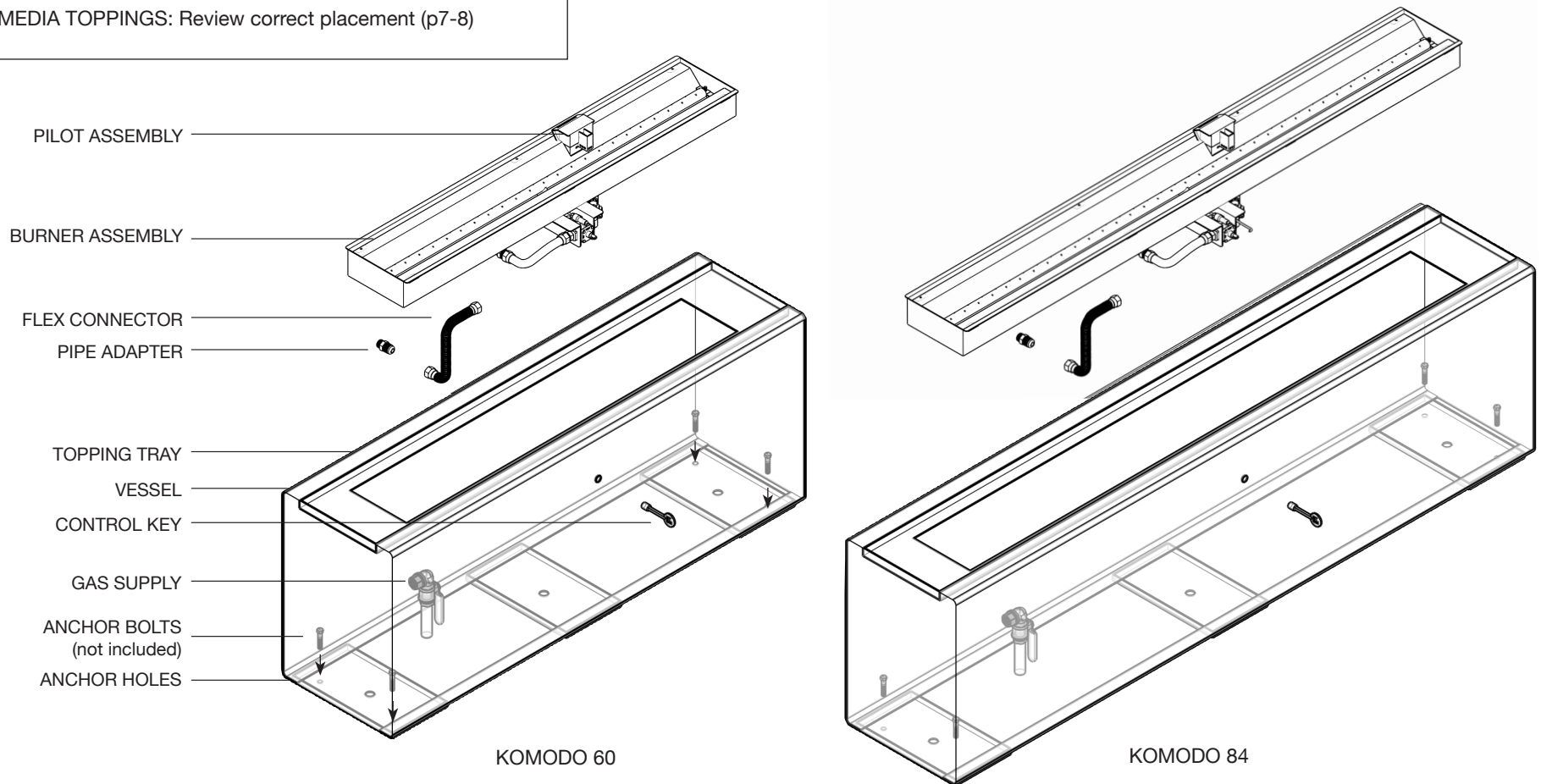

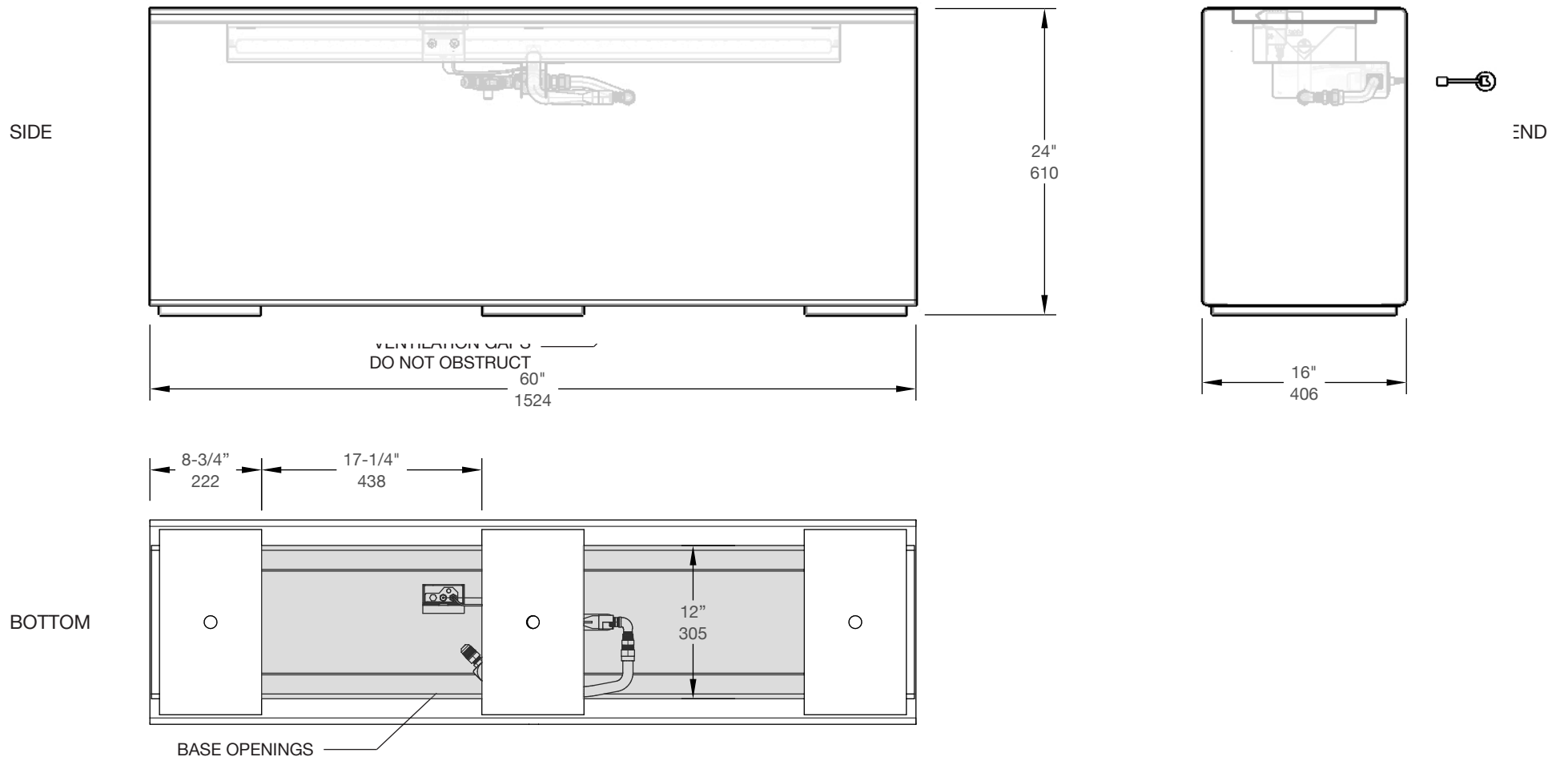

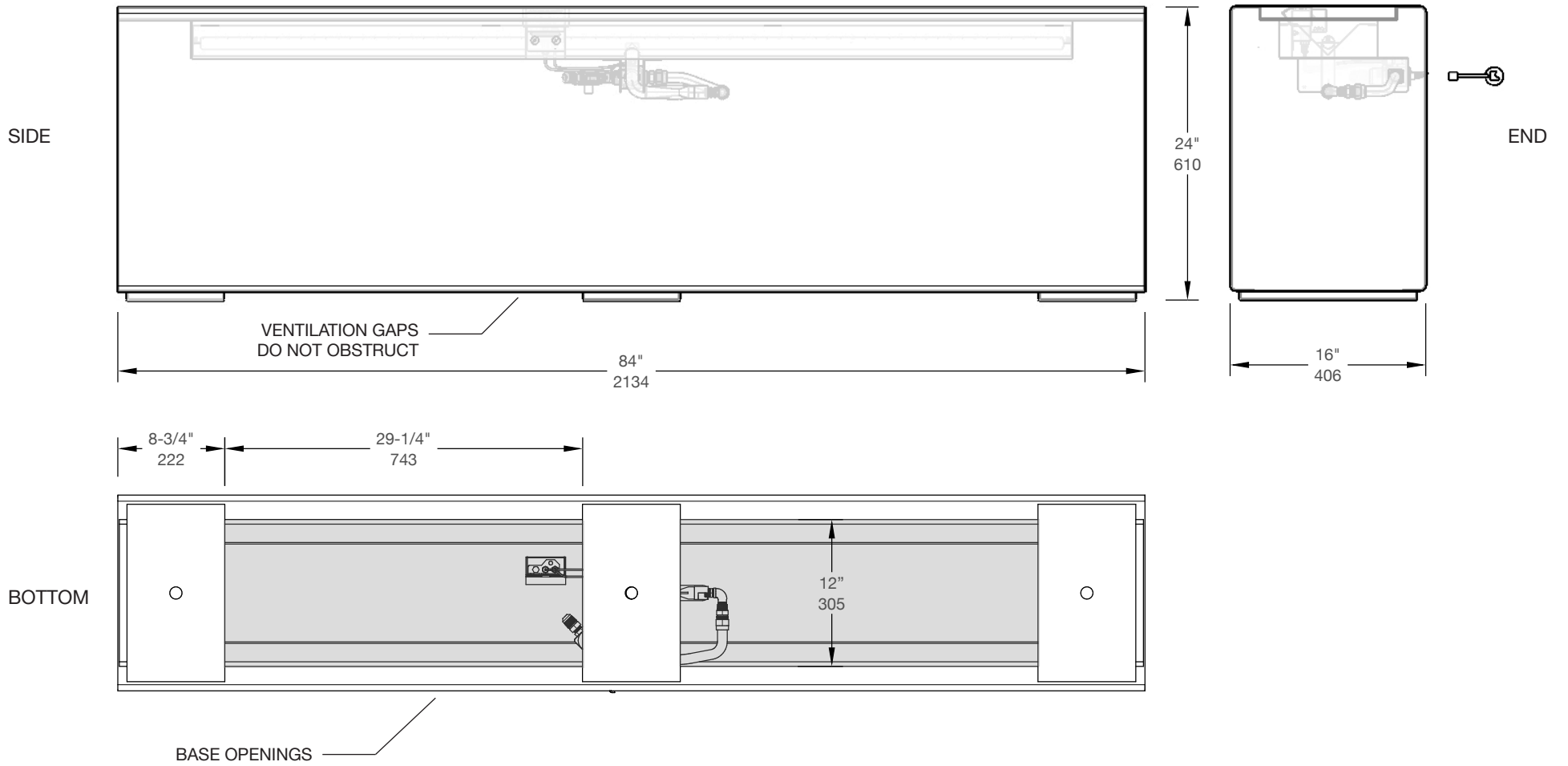

	KOMODO 60 NATURAL GAS	KOMODO 60 PROPANE	KOMODO 84 NATURAL GAS	KOMODO 84 PROPANE
Burner Model #	LIN-48	LIN-48P	LIN-72	LIN-72P
Heat Input	G20, 20 mbar 27 kW	G31, 37 mbar 25 kW, 1758 gr/h	G20, 20 mbar 40 kW	G31, 37 mbar 31 kW, 2169 gr/h
Burner Pressure	8.7 mbar	25 mbar	8.7 mbar	25 mbar
Orifice Size	18	37	4	31
Burner Ports	47	47	71	71
Port Size	1/8" (~3 mm)	1/8" (~3 mm)	1/8" (~3 mm)	1/8" (~3 mm)

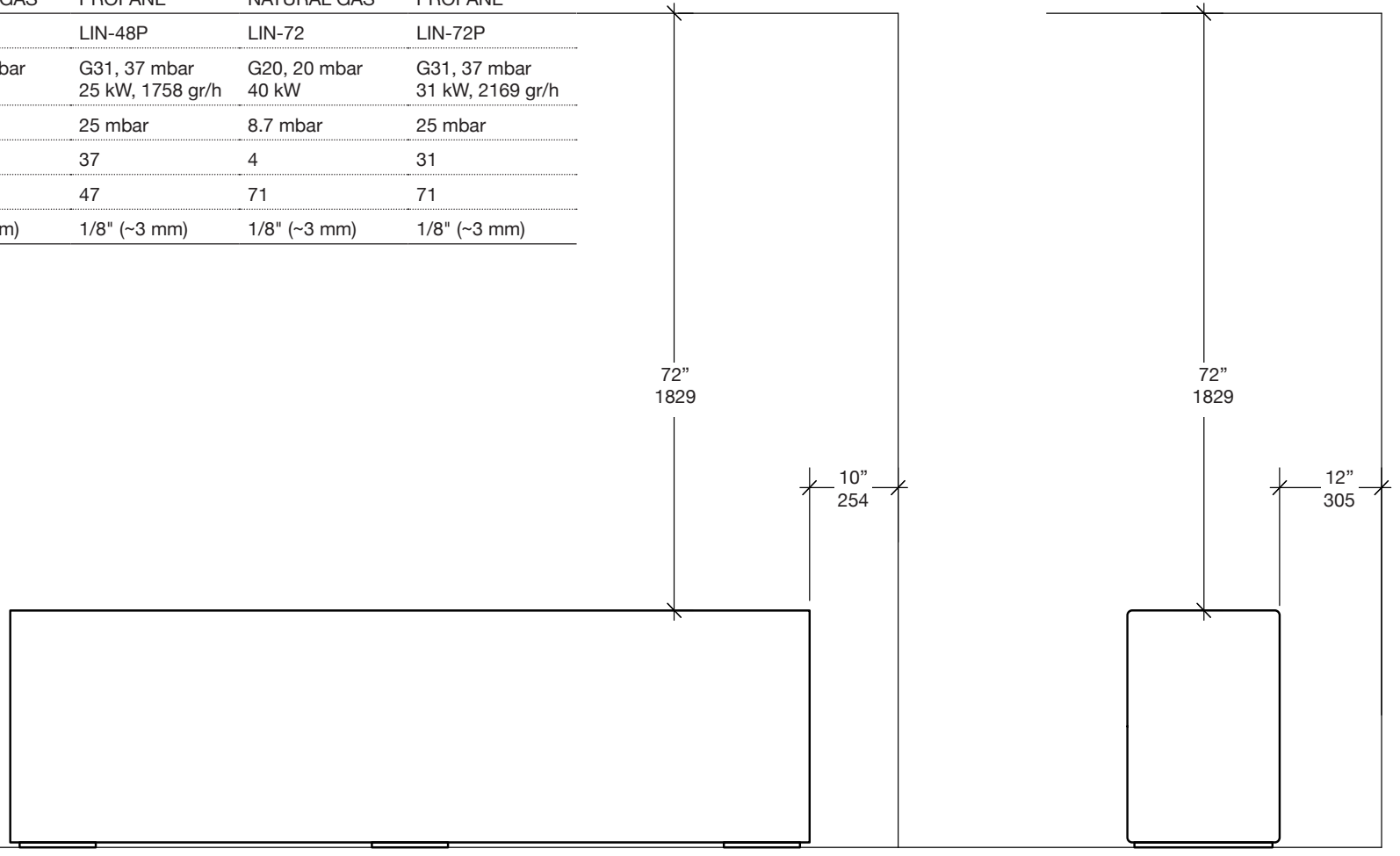

0 mm CLEARANCE BELOW

MINIMUM CLEARANCES TO COMBUSTIBLES

**WARNING:**

Failure to position parts in accordance with these diagrams and instructions and/or failure to use parts specifically approved for use with this appliance may result in property damage or personal injury.

Do not remove the data plates attached to the Outdoor Fire Pit Burner. These plates contain important information.

**NOTICE:**

Installation and repair should be done by a qualified service person. The appliance should be inspected before use and at least once annually by a qualified service person. More frequent cleaning may be required as necessary. It is imperative that control compartment, burner ports and circulating air passageways of the appliance be kept clean.

**CAUTION:**

New Lava Rock may pop or crackle when first heated. This should subside after 30 minutes to one hour or more of operation. Maintain safe distance during this time.

**TO ASSEMBLE THE FIRE PIT**

1. Assemble fire pit housing per diagram on page 3.
2. Connect the Burner Assembly to the gas supply using the supplied flex connector, following the instructions on p 9.
3. Carefully leak test all connections following the procedure on p 9. Check the air shutter on venturi. For NG it is sealed. For LP it is fully open (see part 2a, pg 14)
4. Fill the burner trough evenly with burner media (crushed tempered glass for natural gas; volcanic rock for propane). Do not obstruct the pilot ignition port with burner media! Do not use media not supplied by Paloform!
5. Place the burner assembly on a stable surface. Ensure burner is level.
6. Follow the Initial Lighting Instructions on page 10. Make sure that the flame is even along the burner length and appliance is fully operational and safe for use. Turn OFF the appliance and let it cool before proceeding to the next step.
7. Carefully lift the burner and place it in the Robata body. (See page 3)
8. Place and evenly distribute decorative topping media (lava rock or tempered glass pebble) on top of burner media. (See page 8). Decorative media should be brought level with the top of the pilot cover. An uneven or excessively thick layer of topping can result in an uneven flame.  
Do not obstruct PILOT IGNITION PORT!
9. Correct flame appearance:

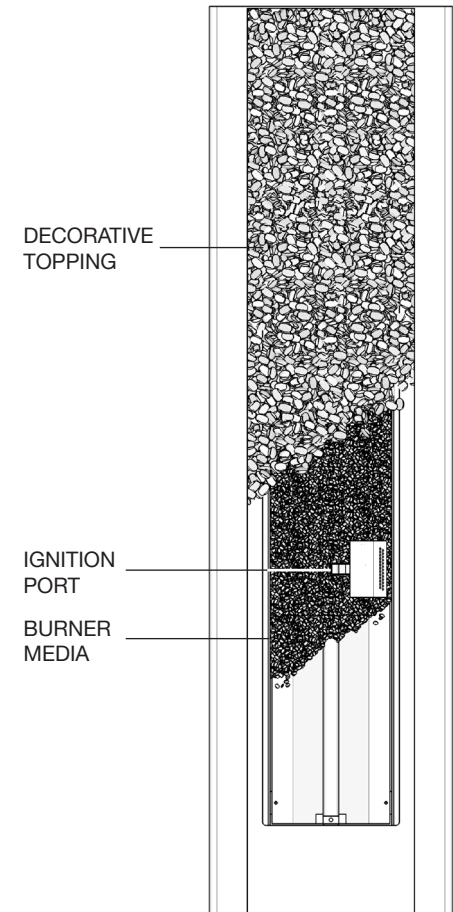

DECORATIVE TOPPING MEDIA (VARIOUS):  
FILL TOPPING TRAY  
- COVER BURNER MEDIA

BURNER MEDIA:  
CRUSHED GLASS (NG); LAVA ROCK (LP)  
- FILL BURNER MEDIA TRAY

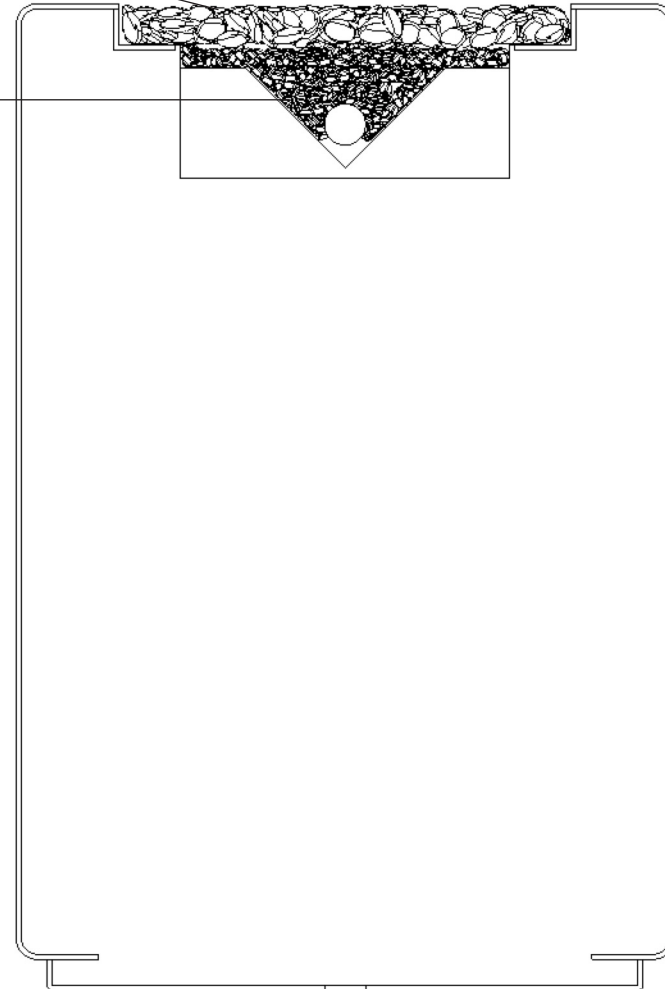

**CAUTION:** Do not use any media over the burner that have not been supplied by Paloform. Landscape stone or other natural or manufactured materials may explode when heated.



## WARNING:

A qualified service person must connect the appliance to the gas supply. Follow all local codes.

## CAUTION:

Use only new black iron or steel pipe. Internally tinned copper tubing may be used in certain areas. Use pipe of 1/2" diameter or greater to allow proper gas volume to Outdoor Fire Pit Burner. If pipe is too small, undue loss of pressure will occur.

## INSTALLATION ITEMS NEEDED:

Before installing the Outdoor Fire Pit, make sure you have all items listed below:

- piping (check local codes)
- sealant
- manual shutoff valve
- adjustable (crescent) wrench or pliers
- sediment trap
- tee joints
- pipe wrench

## INSTALLATION REQUIREMENTS

This appliance must be installed and serviced by trained gas installation and service technician only. All pipework must be supported and installed in accordance with local and/or national regulations.

- The gas supply to the appliance must terminate with an isolation cock and a flexible connector. This will allow the appliance to be disconnected for maintenance or repair. The appliance is supplied with a 1/2" BSP male pipe fitting.
- Check that the main gas supply line is of proper diameter to supply the required fuel pressures. Pipes of a smaller size than the heater inlet gas connection must not be used.
- If utilizing used pipe, verify that its condition is clean and comparable to a new pipe. Test all gas supply lines in accordance with local codes.
- Test and confirm that inlet pressures are correct. Refer to the heater data plate and packaging to verify fuel type.
- Install a sediment trap/drip leg for condensation which may occur at any point of the gas supply line. This will decrease the possibility of loose scale or dirt in the supply line entering the appliance's control system and causing a malfunction.

## CHECKING GAS CONNECTION

**WARNING:** Test all gas piping and connections for leaks after installing or servicing. Correct all leaks immediately.

**WARNING:** Never use an open flame to check for a leak. Apply a mixture of liquid soap and water to all joints. Bubbles forming on joints while the gas is running indicate a leak. Correct all leaks at immediately.

### Test Pressures in Excess Of 37 mbar

This appliance and its individual shutoff valve must be disconnected from the gas supply piping system during any pressure testing of that system at test pressures in excess of 37 mbar.

### Test Pressures Equal To or Less Than 37 mBar

This appliance must be isolated from the gas supply piping system by closing its individual manual shutoff valve during any pressure testing of the gas supply piping system at test pressures equal to or less than 37 mbar.

**WARNINGS:**

Failure to follow these instructions exactly may result in fire or explosion causing property damage, personal injury or loss of life.

---

Before operating the appliance, check all around the appliance area and on the surrounding floor for the smell of gas - some gas is heavier than air and may settle on the floor in the event of a leak. **IF YOU SMELL GAS**, follow the safety instructions on page 1 of this manual.

---

This appliance is equipped with an ignition device that automatically lights the pilot. Do not try to light the pilot manually.

---

Do not use this appliance if any part of it has been under water. Immediately call a qualified service technician to inspect the appliance and to replace any part of the control system and any gas control that has been under water.

---

Improper installation, adjustment, alteration, service or maintenance can result in injury or property damage. For assistance or additional information, consult a qualified installer, service agency or the gas supplier.

---

Do not store or use gasoline or other flammable vapors or liquids in the vicinity of this appliance.

**INITIAL LIGHTING INSTRUCTIONS**

Before placing burner assembly into a housing:

1. Purge air from the supply line.
2. Test for leaks in each of the following locations:
  - The gas supply line connection to the main valve;
  - The Burner connections and pilot;
  - All joints on the valve and control body;
  - All field made joints and gas shutoff valves;
  - All factory made joints and connections.
3. You may check for gas leaks using one of the following methods only:
  - Soap and water solution. **WARNING: If using a soap and water solution to test for leaks, DO NOT spray the solution onto electronic parts;**
  - An approved leak testing spray;
  - An electronic sniffer. **NOTE:** Remove any excess pipe compound from connections if using this method, as the compound can set off electronic sniffers.

**DANGER: NEVER USE AN OPEN FLAME TO CHECK FOR GAS LEAKS.**

## STOP!

Review the safety information on pages 1, 2 and 10 of this manual.

Use only your hand to push in or turn the gas control key. Never use tools. If the key will not push in or turn by hand, don't try to repair it, call a qualified service technician. Force or attempted repair may result in a fire or explosion.

Please ensure that you are familiar with the safe operation of the fire pit controls before replacing the instructional control knob with the Paloform key.

The control key/knob is meant to fit tight and be left in place. Remove only for winterization.

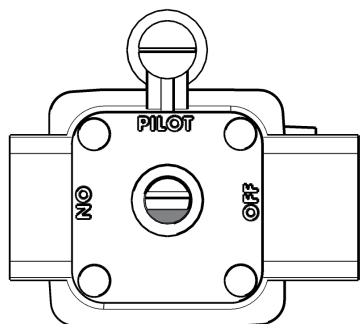

VALVE POSITIONS

The gas valve has three positions: PILOT, ON and OFF.

To light your fire pit, you first light the pilot flame, then turn on the gas to main burner.

1. Insert the control key (or control knob). Make sure the "half-moon"-shaped hole in the end of the key and the valve stem are aligned.
2. The key should turn freely 90°. Turn the key to the PILOT position (clockwise until it stops)
3. Push the control key in until it stops, and hold in this position.
4. Apply a flame to the lighting port with a barbecue lighter. The pilot flame will ignite.
5. Continue to hold the key down for up to thirty seconds after lighting the pilot.
6. When the control key is released, the pilot flame should continue to burn (if the pilot goes out, repeat the above steps).
7. Rotate the gas control key from PILOT to ON position (full counterclockwise position) to supply full flow to main burner.
8. To extinguish main burner, rotate the gas control key clockwise to the PILOT position.
9. To extinguish pilot, push the control key in slightly and turn to the OFF position (fully clockwise).

Failure to turn the control key to the full ON position will reduce the flow and could result in poor ignition of main burner.

NOTE: We do not recommend leaving the fire pit unattended with the pilot lit. Please turn to the OFF position.

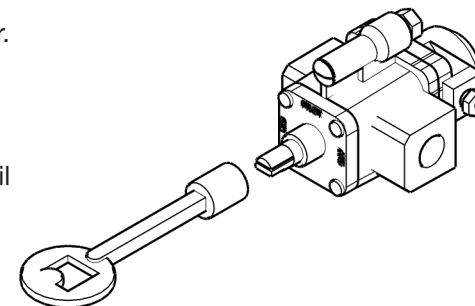

PILOT

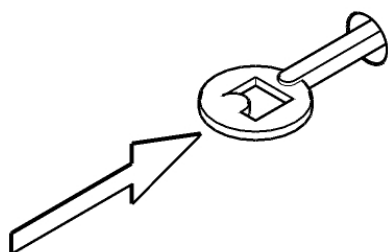

Push key in PILOT position to start the flow of gas to the pilot. Light the pilot while holding the key in

ON

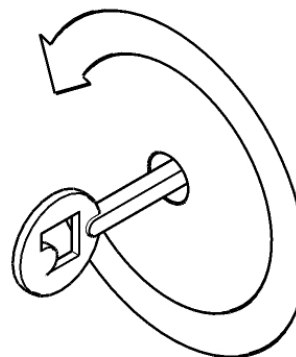

Turn the key 90° counter-clockwise to turn on the main burner. To turn the main burner off, turn clockwise 90° back to the PILOT position

OFF

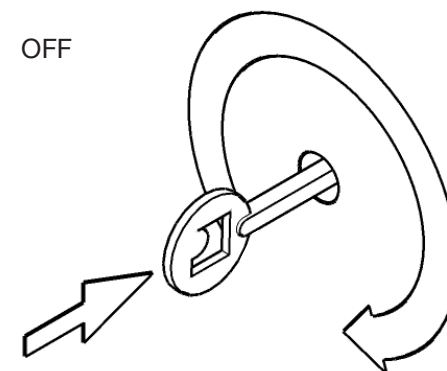

To turn the pilot off, push slightly and turn clockwise 90° to the OFF position.

## KEEP YOUR FIRE PIT COVERED

Covering your fire pit with its all-weather cover when not in use will prolong the life of all its components.

**WARNING:** Turn off gas before servicing fire pit.

We recommend that a qualified service technician perform the following check-ups at the beginning of each fire pit season.

If any irregularities are apparent with operation. Please refer to Troubleshooting guide, page 13.

## BURNER ELEMENT AND PILOT

Keep the burner and pilot area clean by vacuuming or brushing at least twice a year. Make sure the burner porting and burner air openings are free of obstructions at all times. Remove pilot cover to inspect pilot.

Remove topping from top of burner ring and inspect area around the burner. Remove any lint or foreign material with a brush or vacuum cleaner.

## PILOT FLAME

The flames from the pilot should be visually checked as soon as the unit is installed, and periodically during normal operation. The pilot flame must always be present when the fire pit is in operation. The pilot flame has two distinct flames: one engulfing the thermocouple and the other reaching to the main burner.

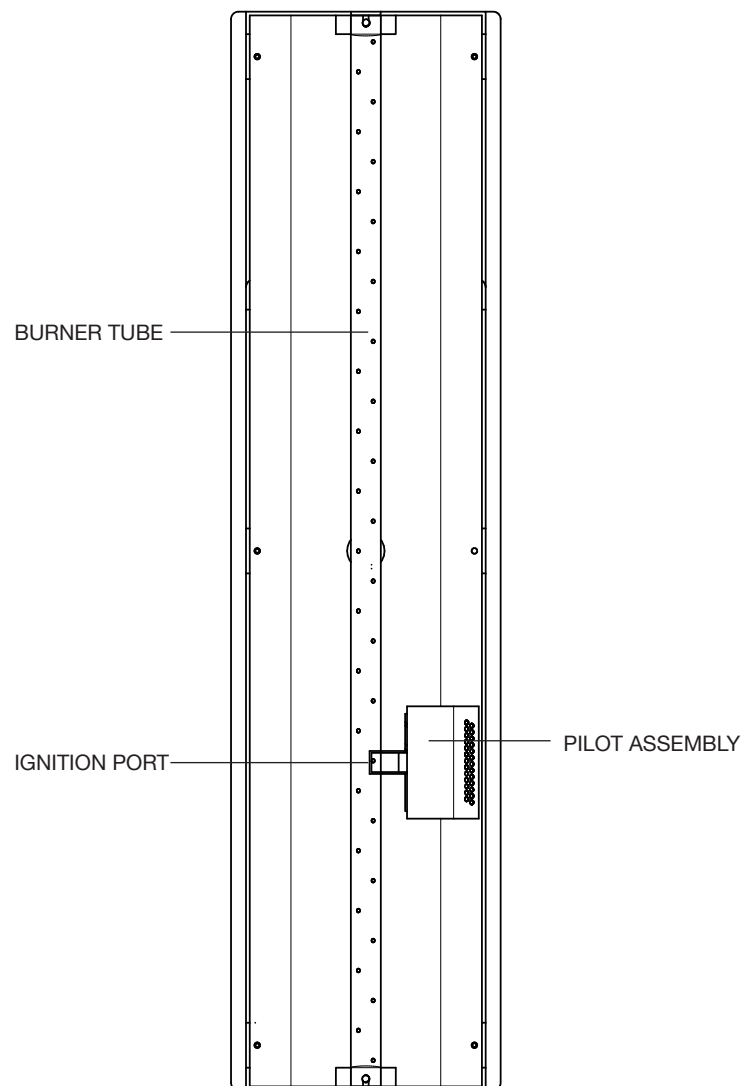
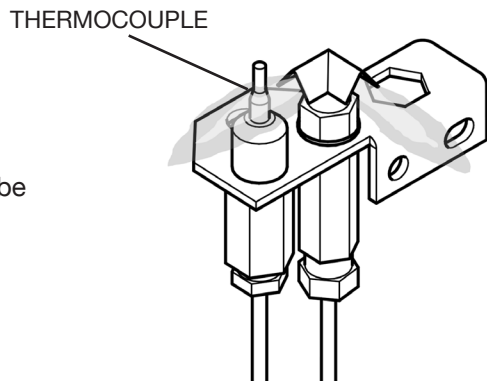

**WARNING:**

Turn off appliance and let cool before servicing. Only a qualified service person should service and repair this appliance.

**IMPORTANT:** Operating unit where impurities in air exist may create odors. Cleaning supplies, paint, paint remover, cigarette smoke, cements and glues, new carpet or textiles, etc., create fumes. These fumes may mix with combustion air and create odors. These odors will disappear over time.



**IF YOU SMELL GAS:**

Shut off gas supply.  
Do not try to light any appliance.  
Do not touch any electrical switch; do not use any phone in the vicinity of the appliance.

Immediately call your gas supplier from a safe distance. Follow your gas supplier's instructions.

OBSERVED PROBLEM	POSSIBLE CAUSE	REMEDY
Unit is smoking / sooting excessively. (Note: It is natural and unavoidable for appliance sets to produce moderate levels of carbon (soot) where flames contact the media.)	<ol style="list-style-type: none"> <li>Poor fuel quality</li> <li>Excessive flame impingement or blockage</li> <li>Improper fuel/air mixture</li> </ol>	<ol style="list-style-type: none"> <li>Contact local natural gas company</li> <li>Separate the stones to allow more flame passage</li> <li>Remove any foreign items from the flame pattern and/or check for proper orifice sizing</li> </ol>
Burner is excessively noisy (Note: The movement and combustion of gas will create low, unavoidable levels of noise.)	<ol style="list-style-type: none"> <li>Passage of air/gas across irregular surfaces</li> <li>Excessive gas pressure on natural gas units</li> </ol>	<ol style="list-style-type: none"> <li>Relieve any tight bends or kinks in gas supply line</li> <li>Check/reset gas regulator pressure</li> </ol>
Gas odor even when manual valve is in the OFF position	<ol style="list-style-type: none"> <li>Gas leak. See Warning statement below.</li> <li>Main gas valve defective.</li> </ol>	<ol style="list-style-type: none"> <li>Locate and correct all leaks (see <i>Checking Gas Connections, pg 8</i>)</li> <li>Replace gas valve</li> </ol>
Unit produces unwanted odors	<ol style="list-style-type: none"> <li>Gas leak. See Warning statement below.</li> </ol>	<ol style="list-style-type: none"> <li>Locate and correct all leaks (see <i>Checking Gas Connections, pg 8</i>)</li> </ol>
Pilot cannot be lit	<ol style="list-style-type: none"> <li>Gas supply turned off or manual shutoff valve closed</li> <li>Air in gas lines when installed</li> <li>Pilot adjustment screw closed</li> <li>Pilot is clogged</li> </ol>	<ol style="list-style-type: none"> <li>Turn off gas supply or open manual shutoff valve</li> <li>Purge air from the supply line</li> <li>Adjust pilot flame for approximately 1" blue flame</li> <li>Clean pilot (see <i>Cleaning and Maintenance, page 11</i>) or replace pilot assembly</li> </ol>
Pilot does not stay lit after control is released	<ol style="list-style-type: none"> <li>Flame sensor/thermocouple is not hot enough</li> <li>Thermocouple is damaged</li> </ol>	<ol style="list-style-type: none"> <li>Retry, holding control Okey for a longer period of time (20 seconds or more) before releasing</li> <li>Replace thermocouple</li> </ol>
Burner does not light after pilot is lit	<ol style="list-style-type: none"> <li>Burner orifice is clogged</li> <li>Inlet gas pressure is too low</li> <li>Burner orifice diameter is too small</li> <li>Flame sensor lead loose or disconnected</li> </ol>	<ol style="list-style-type: none"> <li>Clean burner orifice</li> <li>Contact local gas or propane supplier</li> <li>Replace burner orifice</li> <li>Reconnect or tighten lead</li> </ol>
Delayed burner ignition	<ol style="list-style-type: none"> <li>Pilot flame is obstructed</li> </ol>	<ol style="list-style-type: none"> <li>Clear media/debris from lighting port</li> </ol>
Burner flame is too low	<ol style="list-style-type: none"> <li>Incorrect gas supply or pressure</li> <li>Blocked burner orifice or burner ports</li> <li>Improper burner orifice size</li> </ol>	<ol style="list-style-type: none"> <li>Check for proper gas supply pressure</li> <li>Free burner orifice and burner ports of any burrs, paint, or other blockage</li> <li>Verify proper burner orifice sizing (see <i>page 4</i>)</li> </ol>

# ILLUSTRATED PARTS LIST

		Natural Gas	Propane
1	Pilot Cover	LIN-EPC	same
1a	Pilot Shroud	LIN-EPC	same
2	Burner Tube	LIN-(48 or 72)-ASSY	same
2a	Air Shutter	-	-
3	Orifice	FIT-ORI-(18 or 4)	FIT-ORI-(36 or 31)
4	Media Tray	LIN-(48 or 72) -ASSY-A	same
5	Burner Tray	LIN-(48 or 72) -ASSY-B	same
6	Pipe Adpater	-	-
7	Pilot Assembly	PIL-M-388	PIL-M-388LP
8	Regulator	M-REG-RV20-NG	M-REG-RV20-LP
9	3/8" Close Nipple	-	-
10	Valve Bracket (set of 2)	BEN32-BRA-WR109	same
11	3/8" 135° Street Elbow	-	-
12	Main Gas Valve	M-VAL-WR-764-109	same
13	Control Key	M-KEY-WR109	same
14	3/8" Street Elbow	-	-
15	Flex Connector	CON-SS-5MM-24	same
16	Burner Media (not shown)	Crushed Glass	Lava Pebbles
17	Topping Media (not shown)	Various	Various
18	Fabric Cover (not shown)	COV-KOM(60 or 84)-LC	same
19	Metal Cover	see p. 3	same
20	Vessel (not shown)	KOM84-(colour code) KOM60-(colour code)	same

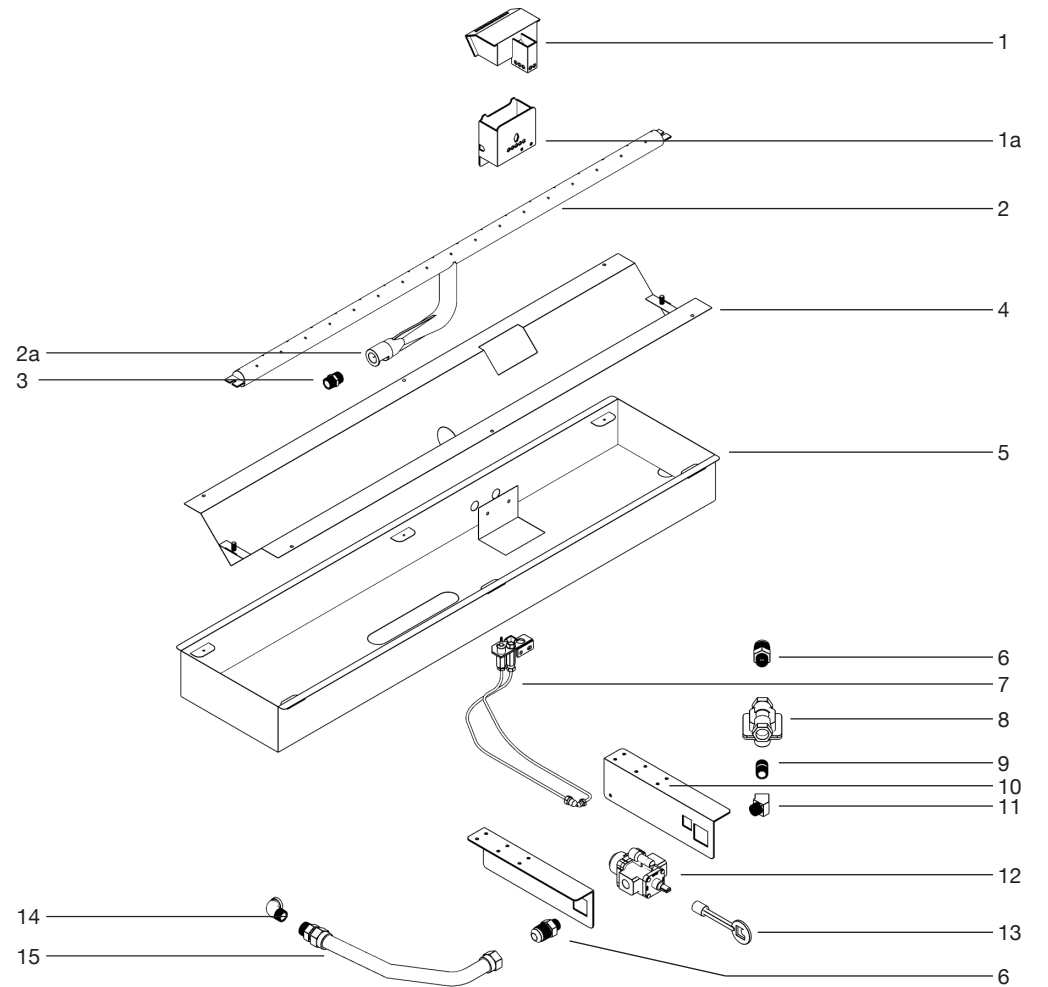

**WARNING:** Failure to position parts in accordance with diagrams or failure to use parts specifically approved for this appliance may result in property damage or personal injury.

REPLACEMENT PARTS ARE AVAILABLE FROM PALOFORM

## RETAIN FOR WARRANTY

MODEL: (circle) Komodo 60/84-M

Natural Gas

Propane

SERIAL NO: \_\_\_\_\_

DATE PURCHASED: \_\_\_\_\_

Paloform's priority is to meet or exceed your expectations with our products and service—we take pride in our products and unequivocally stand behind them. If your product has issues, we will work with you to make things right.

This said, fires pit's are mechanical appliances that are installed in uncontrolled and unpredictable environments. For this reason it is critical that your unit be inspected by a qualified service technician regularly, dependent on use and site conditions, but at minimum once per year. This will ensure that it receives the type of general cleaning and maintenance that will maximize its performance and lifespan. Furthermore, there are various "wear" components which have a limited lifespan due to the fact that their function is to sustain extreme conditions. Over the functional life of your fire pit, you can expect that parts such as pilots, control devices and valves, may need to be replaced periodically. Materials such as cast concrete and Corten Steel are expected to weather naturally over their lifetime and changes in appearance are normal and do not constitute failure in the materials.

### **WARRANTY - This product is warranted to the original owner, subject to proof of purchase:**

Paloform warrants the components and materials in your appliance to be free from manufacturing and material defects for a period of one year from date of delivery. During this time, if any of the components in the appliance are found to be defective in materials or workmanship, Paloform will, at its option, replace or repair the defective components at no charge to the original owner. Paloform will also pay for reasonable labor cost incurred in replacing or repairing such components. Any products presented for warranty repair must be accompanied by a dated proof of purchase.

This Warranty will be void if:

- the appliance is not installed by a qualified installer in accordance with installation instructions.
- the appliance is not operated and maintained according to the operating instructions supplied with the appliance, including regular inspections by a qualified technician
- the appliance is damaged by accident, neglect, misuse, abuse, alterations, negligence of others, including the installation thereof by unqualified installers, incidental or consequential damage
- the appliance is partially or totally submerged under water for any length of time

This Warranty does not cover normal wear and tear, including but not limited to extraordinary environmental factors such as salt-saturated environments or extreme weather events.

All service work must be performed by an qualified service technician.

Paloform reserves the right to investigate any and all the claims against this Warranty and decide upon method of settlement. For information about this warranty contact:

Paloform Distribution (UK) Limited | +44 (20) 37957751 | [info@paloform.co.uk](mailto:info@paloform.co.uk) | [paloform.co.uk](http://paloform.co.uk)  
Unit 6B Metnor business Park  
Hadrian Road  
Wallsend NE286HH  
United Kingdom