

Technical Data

Burner Model:

Heat Output:

Clearances to Combustibles:

Available Finishes:

Available Accessories:

Burner Certifications & Standards:

Installed Weight:

Crated Weight:

Crate Size:

Vessel Material & Weight:

Natural Gas

LIN-E-48

80,000 BTU/h / 25 kW

Above: 72" Below: 0" Sides: 8"

Corten Steel

Tempered Glass Screen

US & Canada - ETL ANSI Z21.97 CSA 2.4.1

UK & EU - CE GAR (EU) 2016/426; Switzerland - SVGW

up to 425 lbs | 190 kg

up to 570 lbs / 260 kg

78"x30"x21"h / 198x76x53 cm

Corten Steel 250 lbs / 115 kg

Propane

LIN-E-48P

77,000 BTU/h / 25 kW

For more information, visit paloform.com/fire-pits/robata-corten



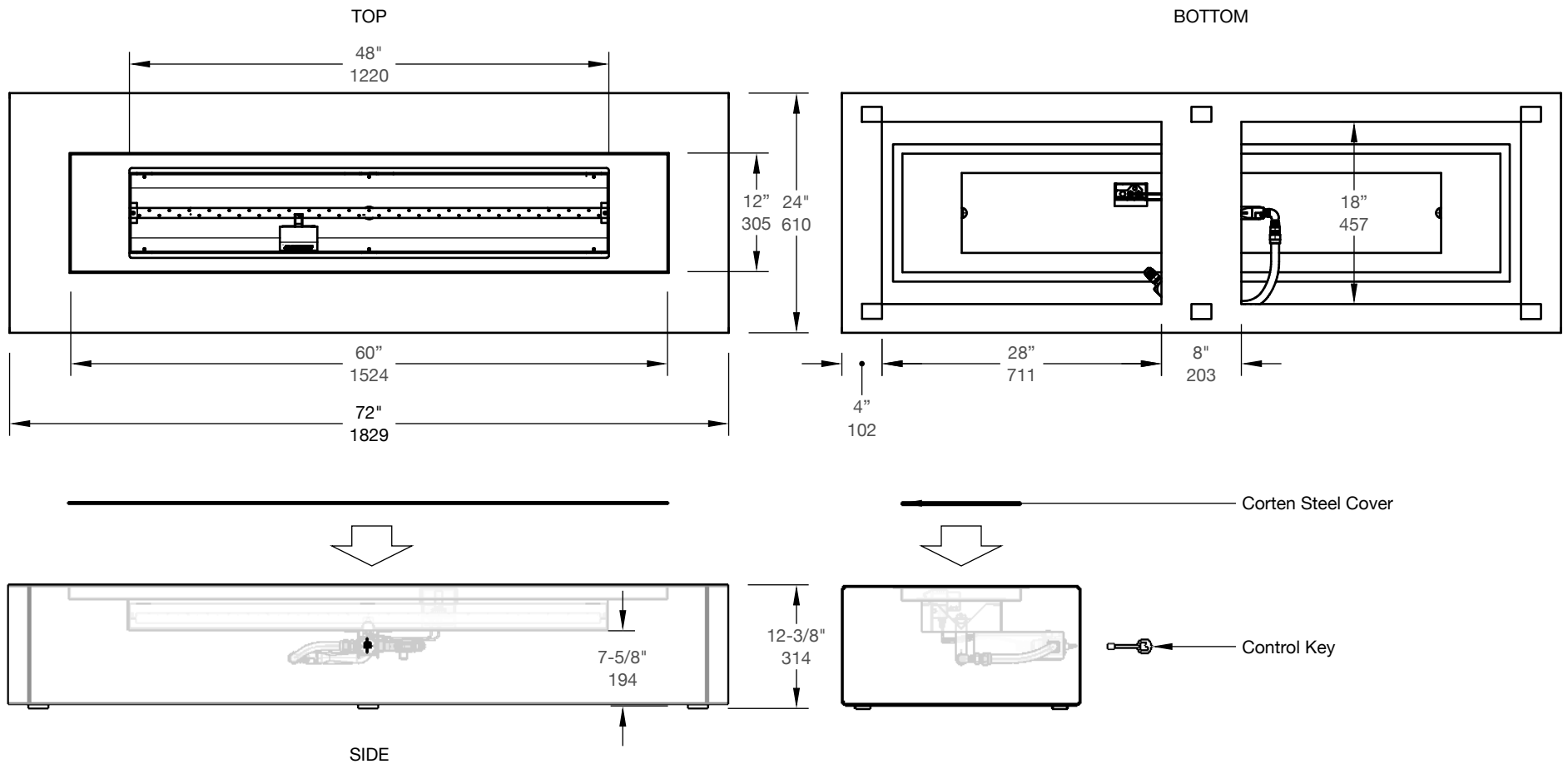

Technical Data

	Natural Gas	Propane
Burner Model:	LIN-M-48	LIN-M-48P
Heat Output:	80,000 BTU/h / 25 kW	77,000 BTU/h / 25 kW
Clearances to Combustibles:	Above: 72" Below: 0" Sides: 8"	
Available Finishes:	Corten Steel	
Available Accessories:	Tempered Glass Screen	
Burner Certifications & Standards:	US & Canada - ETL ANSI Z21.97 CSA 2.4.1 UK & EU - CE GAR (EU) 2016/426; Switzerland - SVGW	
Installed Weight:	up to 425 lbs 190 kg	
Crated Weight:	up to 570 lbs / 260 kg	
Crate Size:	78"x30"x21"h / 198x76x53 cm	
Vessel Material & Weight:	Corten Steel 250 lbs / 115 kg	

For more information, visit paloform.com/fire-pits/robata-corten

