

LIGHTING INSTRUCTIONS - Match-lit

The gas valve has three positions: PILOT, ON and OFF.

To light your fire pit, you first light the pilot flame, then turn on the gas to main burner.

1. Insert the control key (or control knob). Make sure the "half-moon"-shaped hole in the end of the key and the valve stem are aligned.
2. The key should turn freely 90°. Turn the key to the PILOT position (clockwise until it stops)
3. Push the control key in until it stops, and hold in this position.
4. Apply a flame to the lighting port with a barbecue lighter. The pilot flame will ignite.
5. Continue to hold the key down for up to thirty seconds after lighting the pilot.
6. When the control key is released, the pilot flame should continue to burn (if the pilot goes out, repeat the above steps).
7. Rotate the gas control key from PILOT to ON position (full counterclockwise position) to supply full flow to main burner.

Failure to turn the key to the full ON position will reduce the flow and could result in poor ignition of main burner.

8. To extinguish main burner, rotate the gas control key clockwise to the PILOT position.
9. To extinguish pilot, push the control key in slightly and turn to the OFF position (fully clockwise).

NOTE: We do not recommend leaving the fire pit unattended with the pilot lit. Please turn to the OFF position.

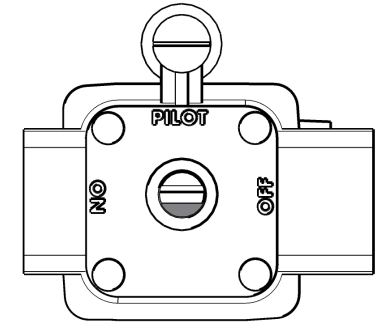

VALVE POSITIONS

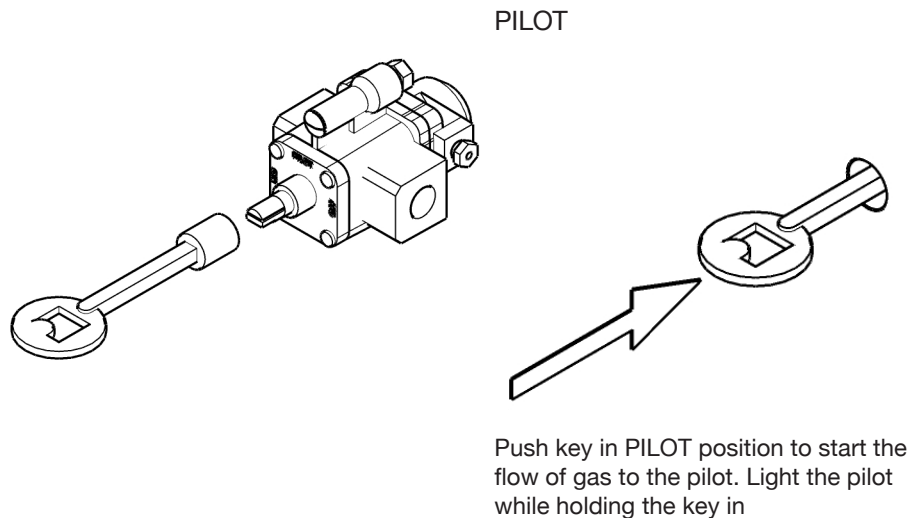

Push key in PILOT position to start the flow of gas to the pilot. Light the pilot while holding the key in

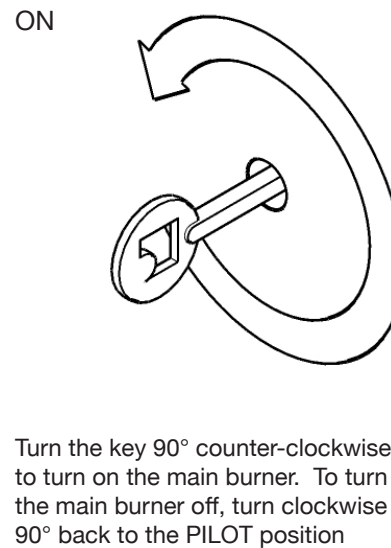

Turn the key 90° counter-clockwise to turn on the main burner. To turn the main burner off, turn clockwise 90° back to the PILOT position

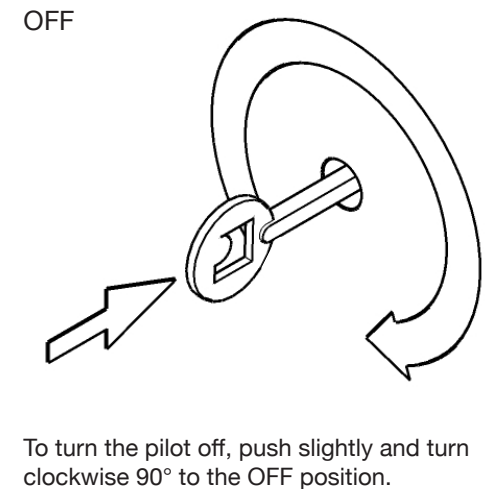

To turn the pilot off, push slightly and turn clockwise 90° to the OFF position.